DMROI

Description of Features

Rev. C, November 21, 2003

Dynatron AG
Unionstrasse 3
CH-8032 Zurich
Switzerland
<http://www.dynatron.biz>

Content

1. Introduction	1
1.1. Typical Frequency Bands.....	1
2. Technical Specialties	2
2.1. Frequency Band	2
2.2. Modulation scheme	2
2.3. Protocol	2
2.4. Data rate.....	3
2.5. Error correcting code.....	3
2.6. Interface DMR01 - microcontroller	3
2.7. Energy consumption.....	3
3. Block diagram examples	4
3.1. Unidirectional data transmission	4
3.2. Bi-directional data transmission	4
4. Connection range	5
5. Advantages of the DMR01 technology	6
6. Examples	7

1. Introduction

1.1. Typical Frequency Bands

0 .. 1 MHz	Long waves: LW-Navigation (Loran etc.), radio clock, air- & sea radio, radio, active RFID, DMR01
1 .. 30 MHz	short- & medium waves: radio, weather radio, air radio, telecommunication, passive RFID, remote control, pager, CB radio
30 .. 2'400 MHz	VHF/UHF: radio, tv, amateur radio, keyless entry, baby phone, telemetric transmitter, short range device, passive RFID, radio phone
> 2'400 MHz	passive RFID, telemetric transmitter, WLAN, movement detector, radar, DMR01 Technology

The DMR01 (Digital Multichannel Receiver) is a chip for wireless data transfer. Multiple transmitters can transmit data to one DMR01. The chip is designed for low data rates and low transmission frequencies. The target of the technology is not to compete against mobile phones or to realize a WLAN. The DMR01 has its benefits in applications where a low energy consumption, relatively short communication range and low prices are important. The DMR01 is a receiver chip that needs an additional micro controller, which gets the received data from the DMR01 and controls the chip. There is no transmitter function integrated in the chip, because the algorithm can be implemented easily in a microcontroller that is most likely already used in the system.

2. Technical Specialties

2.1. Frequency Band

The chip works with a 32kHz clock, which can be received easily from a watch oscillator. Many microcontrollers support already such a clock pin. Using 32768Hz as clock frequency, a possible set of frequency bands can be obtained, in which data can be transmitted. The following center frequencies are possible:

- 8'192Hz
- 24'576Hz
- 40'960Hz
- 57'344Hz
- 73'728Hz
- 90'112Hz
- 106'496Hz
- 122'880Hz
- 139'264Hz

As it can be seen easily, the frequency band is in the long wave band. Therefore, antennas are normally ferrit coils or air coils. With another clock frequency, other frequency bands can be obtained. The only restriction is the frequency range of the input amplifier, which is optimized to receive signals up to approx. 130kHz.

2.2. Modulation scheme

There are different modulation schemes for the transmission of digital signals. A modulation scheme is a procedure to add digital information to a certain carrier frequency. The DMR01 uses differential binary phase shift keying (DBPSK). The digital information is integrated in the phase position of the used frequency. DBPSK is very robust and can be compared to the frequency modulation (FM) which is normally used for analog radio. "Differential" describes the fact, that only the change of information does change the phase of the transmission frequency. The receiver uses an enhanced procedure to receive data also in a very "noisy" environment.

2.3. Protocol

One of the main features of the DMR01 is its ability to distinct and receive multiple transmitters. This is indispensable for a undisturbed transmission, if a number of similar systems are present in the same receiving area. Examples for this are heart rate watches, which tend to malfunction if another person with a similar watch is close.

The DMR01 prevents such problems with its unique protocol. Each transmitter transmits a specific address which allows the DMR01 to distinguish between correct (authorized) and faulty (not authorized) data.

2.4. Data rate

The chip is designed to support data rates of 1kBaud, 2kBaud, 4kBaud or 8kBaud for a 32kHz clock rate.

2.5. Error correcting code

To further enhance the quality of the transmission, there is a possibility to use an error correcting code. Each transmitted bit gets a complementary bit, which is a function of some of the last transmitted bits. The transmission time will be increased by a factor of two (convolutional code with rate 0.5). With this complementary information, the receiver can recognize faulty transmissions and in many cases even correct them.

2.6. Interface DMR01 - microcontroller

To receive a small chip size (a factor that influences the cost of the chip), a simple but common SPI-Interface is implemented. The DMR01 generates an interrupt for the microcontroller when it receives a valid transmission. The microcontroller needs only to get the ready-to-use data from the DMR01 in that case.

2.7. Energy consumption

Because of the low clock rate, the chip needs ultra low power. It is therefore perfectly suited for battery powered units. Of course, it is also a perfect component, if ultra low power is not necessary.

3. Block diagram examples

3.1. Unidirectional data transmission

The DMR01 technology is ideally implemented in systems, which use already their own micro-controller. The transmitter can be realized in a very simple way. Only a driver stage and an antenna are necessary. The transmitter software is not demanding and can be delivered as C-code. On the receiver side, only an antenna and an oscillating circuit must be attached to the DMR01. For longer transmission distances, a simple amplifier should be used to amplify the antenna signal for the DMR01. Fig. 1 shows a possible block schema:

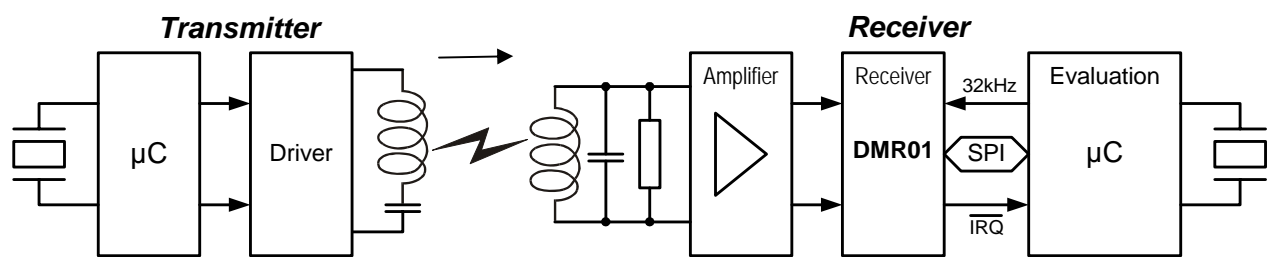

Fig. 1

3.2. Bi-directional data transmission

The DMR01 technology can also be used to establish a bi-directional wireless connection in a simple way. In this case, the transmitter antenna is the same as the receiver antenna. Therefore, the transmitting distance will most likely be a little shorter compared to the unidirectional connection. Fig. 2 shows a possible block diagram for a transceiver:

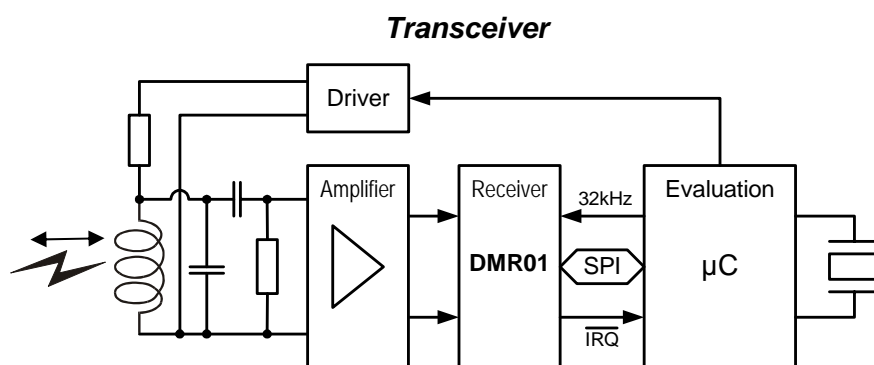

Fig. 2

4. Connection range

The connection distance and the shape of the receiving area can be influenced by the input amplifier, the transmission power and the antenna design. With the size and the type of the antenna (air- or ferrit coil) and with the design of the antenna amplifier, the receiving area can be “tailored” to the needs. Fig. 3 and 4 show the different behavior for ferrit and air transmitter coils in combination with ferrit and SMT receiver coils. For these examples, the input amplifier and the transmission power was not changed.

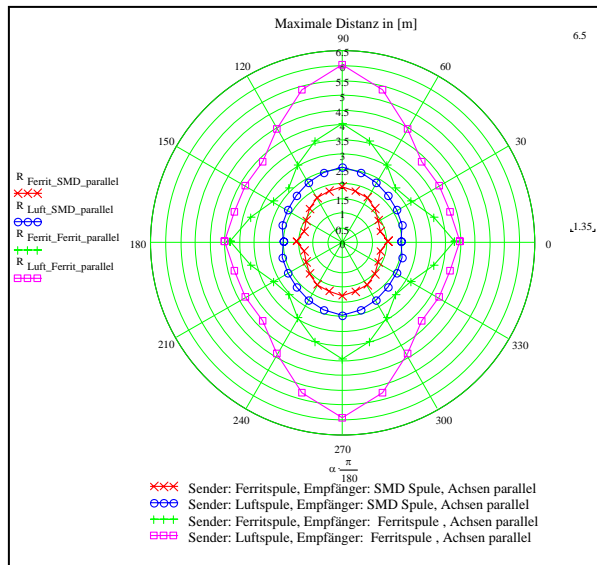

Fig. 3

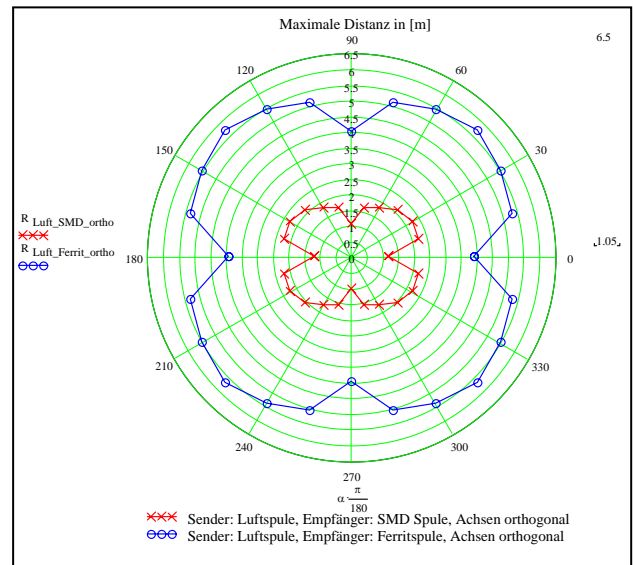

Fig. 4

The design of amplification, transmission power and antennas can be used to further avoid disturbance and to focus the receiving energy on certain areas.

5. Advantages of the DMR01 technology

There are many advantages when using the DMR01 technology:

1. frequency band: Long waves can penetrate conducting materials like seawater, wet ground or metal, higher frequencies not. The low frequencies give you advantages for the registration. The legal regulations are very loose. Below 9kHz, there are no regulations.
2. safety: includes identification (address) and optional coding with error correction
3. energy consumption: Ultra low power consumption (approx. 30µA) enables the use even for battery driven units with small batteries. The chip works down to 2.5V.
4. connection range: Wireless connections are possible up to 10m / 30ft. With the size and the type of the antenna (air- or ferrit coil) and with the design of the antenna amplifier, the receiving area can be "tailored" to the needs.
5. package: The chip is sold in the TSSOP20 package (4.4x7.8mm). For larger quantities, the DMR01 can be delivered as die or in a custom package.
6. simplicity: The system is very simple. A wireless connection using the DMR01 technology can therefore be developed very fast and with a low budget.
7. cost: The chip is low cost. Please contact Dynatron AG for an offer.

6. Examples

The DMR01 can be used in many applications. Examples are:

- Access control
- Alarm systems
- Wireless data transmission in conducting materials (liquids)
- Wireless data transmission around or through the human or animal body
- Detection of position
- Remote control

Dynatron AG
Unionstrasse 3
CH-8032 Zurich
Switzerland
<http://www.dynatron.biz>